

Proven reliability for decades

In pneumatic applications such as cylinders and valves the K-Ring is approved for decades. Use it without risk.

Wide tolerance field

Piston as well as bearing surface can be at tolerance c11/H11, sometimes even larger tolerances are possible. Generally available tubes and bars with a peak-to-valley height of up to 2 µm can be used. Runout is compensated by the K-Ring.

No sealing problems

The K-Ring guarantees a close to 100 % sealing effect given a pressure difference. Changing the pressure direction does not lead to leakage.

Low friction

On average you will lose only 2 % of the force of the piston due to friction. In regulators K-Rings can replace diaphragms.

Lubrication without problems

The special sealing rim makes sure that a lubrication film stays for a long time on the bearing surface. In most cases no re-lubrication is required. In case of questions concerning oils or grease do not hesitate to contact us.

Long life

Several million switches are possible, wear is related to stroke.

Wide temperature range

In a range of -20 °C to +100 °C the use of the NBR-quality is possible, low- as well as high-temperature versions are available.

Standard pressure range

Up to 10 bar, for use with higher pressure please check back.

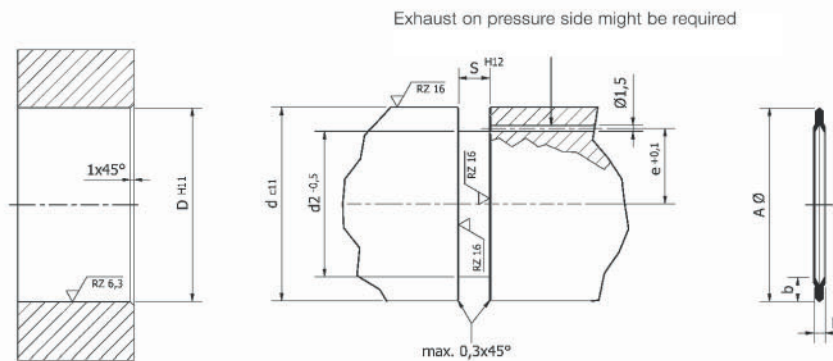

K-Rings – external seal – part of the range

Type	Order-Nr.	Groove				K-Ring			Type	Order-Nr.	Groove				K-Ring		
		D/d ₁	d ₂	s	[e]	A	b	h			D/d ₁	d ₂	s	[e]	A	b	h
KA 12	N 893/12	12	5.5	1.7	3.5	12.5	2.4	1.5	KA63	N 896/63	63	47.0	3.5	24.3	64.0	7.0	3.0
KA 15	N 890/15	15	5.5	2.3	3.5	15.6	3.8	2.0	KA70	N 890/70	70	55.5	3.5	28.5	71.1	6.0	3.0
KA 16	N 890/16	16	6.5	2.3	4.0	16.5	3.8	2.0	KA75	N 896/75	75	59.0	3.5	30.3	76.1	7.0	3.0
KA 18	N 890/18	18	8.5	2.3	5.0	18.6	3.8	2.0	KA80	N 896/80	80	61.0	4.1	31.3	81.2	8.3	3.5
KA 20	N 890/20	20	10.0	2.3	5.8	20.6	3.8	2.0	KA90	N 896/90	90	71.0	4.1	36.3	91.3	8.3	3.5
KA 25	N 890/25	25	15.0	2.3	8.3	25.7	3.8	2.0	KA100	N 890/100	100	79.0	4.6	40.3	101.4	8.1	4.0
KA 26	N 890/26	26	16.0	2.3	8.8	26.7	3.8	2.0	KA105	N 890/105	105	86.0	4.6	43.8	106.4	8.1	4.0
KA 30	N 890/30	30	20.0	2.3	10.8	30.7	3.8	2.0	KA110	N 890/110	110	91.0	4.6	46.3	111.4	8.1	4.0
KA 32	N 890/32	32	22.0	2.3	11.8	32.7	3.8	2.0	KA115	N 890/115	115	92.5	5.1	47.0	116.5	9.5	4.5
KA 35	N 890/35	35	22.5	3.0	12.0	35.8	5.0	2.5	KA125	N 896/125	125	101.0	5.1	51.3	126.6	10.7	4.5
KA 36	N 890/36	36	23.5	3.0	12.5	36.8	5.0	2.5	KA140	N 896/140	140	113.5	5.6	57.5	141.7	11.8	5.0
KA 40	N 890/40	40	27.5	3.0	14.5	40.8	5.0	2.5	KA150	N 890/150	150	125.0	6.2	63.3	151.8	11.8	5.5
KA 42	N 890/42	42	29.5	3.0	15.5	42.8	5.0	2.5	KA160	N 890/160	160	131.5	6.2	66.5	161.8	11.0	5.5
KA 45	N 890/45	45	32.5	3.0	17.0	45.8	5.0	2.5	KA200	N 890/200	200	163.0	8.8	82.3	202.6	16.2	8.0
KA 50	N 890/50	50	37.5	3.0	19.5	50.9	5.0	2.5	KA225	N 890/225	225	189.5	8.8	95.5	227.5	16.0	8.0
KA 55	N 896/55	55	41.0	3.0	21.3	55.9	6.0	2.5	KA250	N 890/250	250	214.5	8.8	108.0	252.7	16.0	8.0
KA 60	N 896/60	60	44.0	3.5	22.8	61.0	7.0	3.0	KA300	N 890/300	300	258.0	10.8	129.8	303.2	19.0	10.0
									KA355	N 890/355	355	313.0	10.8	157.3	358.7	19.0	10.0
									KA406	N 890/406	406	361.0	10.8	181.3	412.0	20.0	10.0

All dimensions in mm.

Other dimensions available on request.

K-Rings – internal seal – part of the range

Type	Order-Nr.	Groove				K-Ring		
		D/d ₁	d ₂	s	[e]	l	b	h
Ki 6	N 891/06	6	15.5	2.3	7.0	5.4	3.8	2
Ki 9	N 891/09	9	18.5	2.3	8.5	8.4	3.8	2
Ki 10	N 891/10	10	19.5	2.3	9.0	9.4	3.8	2
Ki 12	N 891/12	12	21.5	2.3	10.0	11.4	3.8	2
Ki 16	N 897/16	16	27.0	2.3	12.7	15.4	4.5	2
Ki 20	N 891/20	20	29.5	2.3	14.0	19.2	3.8	2
Ki 22	N 891/22	22	33.5	2.3	15.0	21.1	3.8	2
Ki 25	N 891/25	25	34.5	2.3	16.5	24.4	3.8	2
Ki 30	N 897/30	30	41.0	2.3	19.7	29.3	4.5	2
Ki 32	N 897/32	32	43.0	2.3	20.7	31.3	4.5	2
Ki 40	N 891/40	40	52.0	3.0	25.2	39.2	5	2.5
Ki 45	N 897/45	45	59.0	3.0	28.7	44.2	6	2.5
Ki 50	N 897/50	50	64.0	3.0	31.2	49.1	6	2.5
Ki 60	N 897/60	60	76.0	3.5	37.2	59.0	7	3.0

All dimensions in mm. Other dimensions available on request.

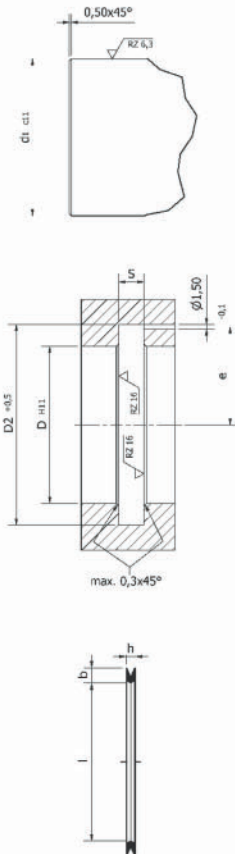

Function of a K-Ring

I The K-Ring is assembled with radial pre-stress. The lips are at the groove wall. Therefore the ring seals also at small pressure difference.

II When inflated pressure can pass the lip. The lip on the opposite side is pressed against the groove wall. Also the sealing rim is pressed against the bearing surface. Increasing pressure increases the sealing effect. This enhances security.

III When pressure is reduced or direction of pressure changes, the pressure inside the sealing system stays high and assures absolute tightness.

* In case low friction at low pressure (< 1 bar) is top priority we recommend to exhaust the sealing system. This can only be recommended if sealing is required in one direction only.

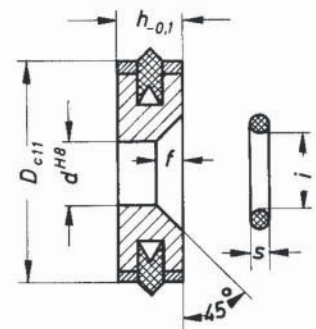

Piston with K-Ring – part of the range

Pistons							Rod Z
Type	Order.-Nr.	D	d	h	f	i x s	
KK 20	1/55601/020	20	6	9	2	6 x 1.5	10
KK 25	1/55601/025	25	6	10	2	6 x 1.5	10
KK 30	1/55601/030	30	10	10	2.8	10 x 2.2	12
KK 35	1/55601/035	35	10	10	2.8	10 x 2.2	12
KK 40	1/55601/040	40	10	10	2.8	10 x 2.2	12
KK 50	1/55601/050	50	12	10	2.7	12 x 2	16
KK 60	1/55601/060	60	12	10	2.7	12 x 2	16
KK 80	1/55601/080	80	16	16	2.7	16 x 2	20
KK 100	1/55601/100	100	20	16	2.7	20 x 2	25
KK 125	1/55601/125	125	24	16	2.7	24 x 2	30
KK 160	1/55601/160	160	30	20	4.1	30 x 3	35
KK 200	1/55601/200	200	30	25	4.1	30 x 3	40

All dimensions in mm.

