



*New Products*

New product

# Capacitance type electromagnetic flow sensor WFC Series



CAPACITANCE TYPE ELECTROMAGNETIC FLOW SENSOR WFC SERIES

## Ultimate "easy operation"



CKD Corporation

CC-1230A

There is no obstacle in the flow path

Analog output  
Switch output

Repeatability  
±0.3ℓ/min (3/8)  
±1.2ℓ/min (1/2, 3/4)

Fluid corresponding to measurement water, water-soluble coolant, etc. (5μs/cm or more)

Flow rate range  
0.5 to 15ℓ/min (3/8)  
2.0 to 60ℓ/min (1/2, 3/4)

Port size  
3/8, 1/2, 3/4  
(Rc, G, NPT)

Capacitance type electromagnetic flow sensor

# WFC Series

## Application example

**Welded** Spot welder

For cooling water management and detection of flow abnormality caused by tip removal of spot welding machine

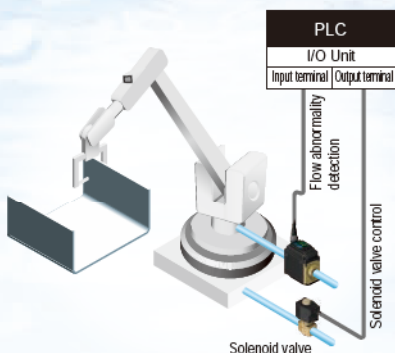

**Machining** All sorts of machine tools

Flow management of the water-soluble coolant

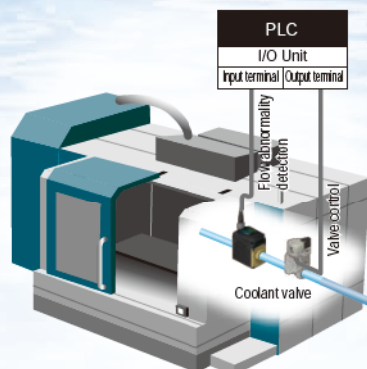

**Hardening** High frequency hardening device

Quantitative management of cooling water

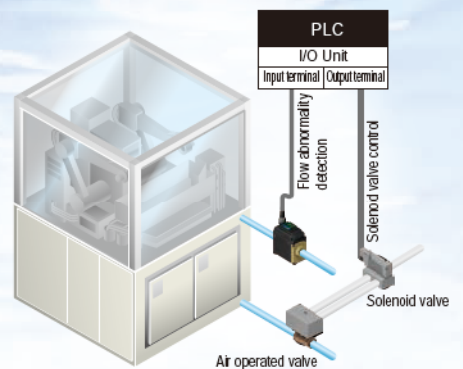

# Flow sensor of through structure

## No clogging of foreign matter

With the through structure adopted, it can be used without problems even in poor water quality.

## No detection failure

Through adoption of electrostatic capacitance type, this structure, detection failure due to foreign matter accumulated on the electrode is reduced.

## Easy installation

Repeatability guaranteed for elbow piping.

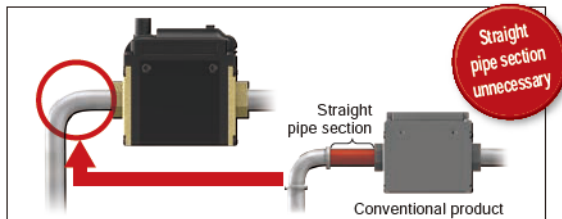

## Remote zero adjust

Zero point adjustment can be carried out through the external input.



## Parallel installation available

With various settings, parallel installation is available.



## Noise resistant type

A stabilized power supply or ferrite core as a noise countermeasure is not necessary.

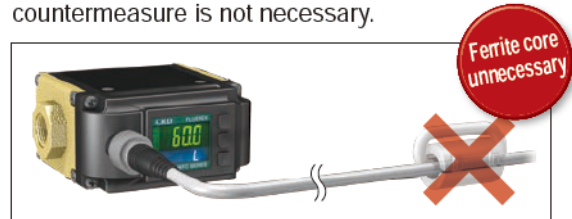

## Display with 180-degree inversion function

Display with flexibility depending on the device.



## Improved visibility

2 color indicator and flow direction arrow enables instant recognition.

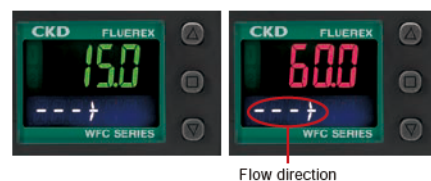

## Equipped with reverse flow detection function

Displays error of reverse flow of fluid and signal output is also available.

## Simple setting

Settings can easily be changed with the short-cut operations.

\* Refer to page 6 for the details.





Capacitance type electromagnetic flow sensor

# WFC Series

• Flow rate range: 0.5~15 • 2.0~60L/min



## Specifications

Descriptions		WFC-150	WFC-600	
Port size		Rc3/8, G3/8, 3/8NPT	Rc1/2, G1/2, 1/2NPT	Rc3/4, G3/4, 3/4NPT
Applicable fluid		Liquid (conductive liquid) that will not corrode the water or materials of wetted part		
Allowable fluid conductivity		5μS/cm or more		
Detection type		Capacitance type		
Rated flow range		0.5~15 L/min	2.0~60 L/min	
Low flow cut		Note 1	3% of maximum flow for measurement range	
Working fluid temperature		0 to 85°C (no freezing)		
Display unit		Instantaneous flow L/min Integrated flow L, kL, ML		
Repeatability		Note 2	±2.0%F.S	
Temperature	Ambient temperature characteristics	Note 2	±5.0%F.S ( 25°C Reference)	
Characteristics	Liquid temperature characteristics	Note 2	±5.0%F.S ( 25°C Reference)	
Working pressure		0 to 1.0MPa		
Proof pressure		2.0MPa		
Response time		Note 3	0.25 s/0.5 s/1 s/2 s/5 s (default value 1s)	
Integrated flow range		0.0 to 99999999.9L		
		0 1L increments		
Pressure loss		0.02MPa or less (At the maximum rated flow)		
Switch output		NPN or PNP transistor output		
	Maximum load current	50mA		
	Maximum applied voltage	30VDC		
	Internal voltage drop	NPN: 2.0V or less PNP: 2.4V or less		
	Output protection	Overcurrent abnormality alarm, overcurrent protection		
	Output mode	Selection from hysteresis mode, window comparator mode, integration output mode, integration pulse output mode and alarm output mode		
Analog output	Voltage output	Voltage output: 1 to 5V load impedance 50kΩ or more		
	Current output	Current output: 4 to 20mA load impedance 500kΩ or less		
Display method		2 screen display (main screen 2 color indicator with green/red, sub screen white) Display update cycle 5 times / s		
Power voltage		24VDC±10% (ripple P-P 10% or less)		
Current consumption		65mA or less		
Environmental resistance	Degree of protection	IP65 equivalent Note 5)		
	Operating ambient temperature	0 to 50°C (with no dew condensation)		
	Operating ambient humidity	35 to 85%RH (with no dew condensation)		
Mounting orientation		Vertical or lateral as desired		
Compatible standard		EC command (EMC command, RoHS command)		
Materials of wetted part		PPS, FKM, CAC804		
Weight (body)		Note 4	Approx. 460g	Approx. 490g
				Approx. 520g

Note 1: Flow rate of less than the low flow cut displays 0L / min.

Note 2: Characteristics when response time is 1s.

Note 3: Response time is up to the stage when it reaches 63% of the value against step input.

Note 4: To use the options, please add the weight of option parts.

Note 5: Degree of protection when cable option: C3 is installed.

Note 6: Please contact us for parallel installation in an interval of 50 mm or less.

Note 7: Piping port and metal part in body are grounded to DC (-) / blue line. It cannot be used with the power of positive grounding.

## How to order

WFC - 150 - 10A - N V - C3

a Flow rate range

b Port size

c Switch output

d Analog output

e Optional (Attachment)

Symbol	Descriptions		
<b>a Flow rate range</b>			
150	0.5 to 15L/min		
600	2.0 to 60L/min		
<b>b Port size</b>			
	Flow rate range	150	600
10*	3/8	●	
15*	1/2		●
20*	3/4		●
<b>* Thread type</b>			
A	Rc thread		
G	G thread		
N	NPT thread		
<b>c Switch output</b>			
N	NPN transistor output		
P	PNP transistor output		
<b>d Analog output</b>			
V	Voltage output (1 to 5V)		
A	Current output (4 to 20mA)		
<b>e Optional (Attachment)</b>			
Blank	None		
C3	Cable (M12 / 4 core / 3m attached)		
B	Bracket attached		

<Example of model no.>

**WFC-150-10A-NV-C3B**

- a Flow rate range : 0.5 to 15L/min
- b Port size : Rc3/8
- c Switch output : NPN transistor output
- d Analog output : Voltage output (1 to 5V)
- e Option : Cable, bracket attached

( Note ) The attachment's symbols will not be described in the model number of the product body.

In the case of WFC-150-10A-NV-C3B

Product body (display) : "WFC-150-10A-NV"

Cable: "WFC-C3"

Bracket: "WFC-B"

"WFC-150-10A-NV-C3B" for three sets of all above will be indicated on a packaging or box.

- Optional (Cable, bracket) model No.

WFC - C3

e Option

# WFC Series

## Internal structure and parts list

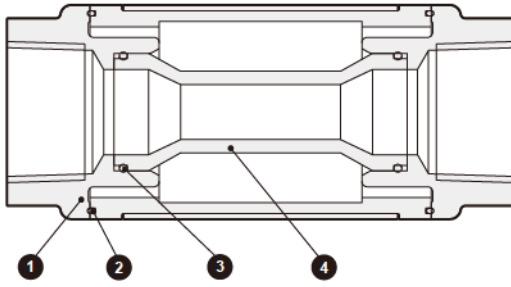

\* Represents the internal structure when the display screen is set to front.

No.	Parts name	Material		Quantity
1	Mouthpiece	CAC804	Brass	2
2	Packing seal	FKM	Fluoro rubber	2
3	O ring	FKM	Fluoro rubber	2
4	Measuring tube	PPS resin		1

## Dimensions

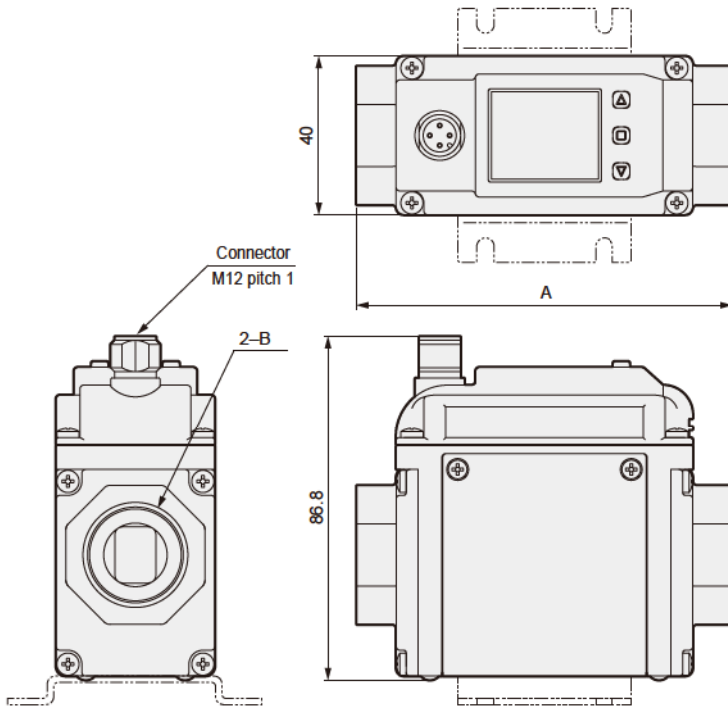

Model no.	A	B
WFC-150-10A	90	Rc3/8
WFC-150-10G		G3/8
WFC-150-10N		3/8NPT
WFC-600-15A	95	Rc1/2
WFC-600-15G		G1/2
WFC-600-15N		1/2NPT
WFC-600-20A		Rc3/4
WFC-600-20G		G3/4
WFC-600-20N	3/4NPT	

## Optional dimensions

### • Cable option

Discrete option model no.: **WFC-C3**

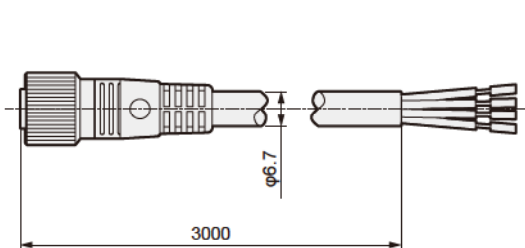

### • Bracket option

Discrete option model no.: **WFC-B**

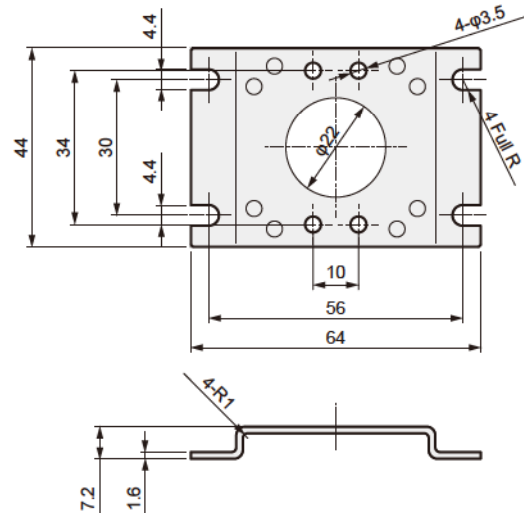

## Wiring method

- Observe the following precautions when wiring.  
 VA connector (model no.: TM-4DSX3HG4) of Correns Corporation is used for connector.  
 Specifications : For DC, 4 core 0.5mm<sup>2</sup>

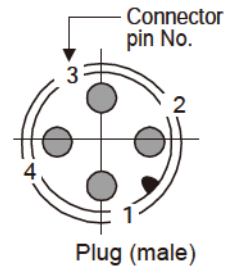

	Switch output type	Analog output
-NV	NPN Transistor output	1-5[V]
-NA		4-20[mA]
-PV	PNP Transistor output	1-5[V]
-PA		4-20[mA]

### 1)-NV, -NA

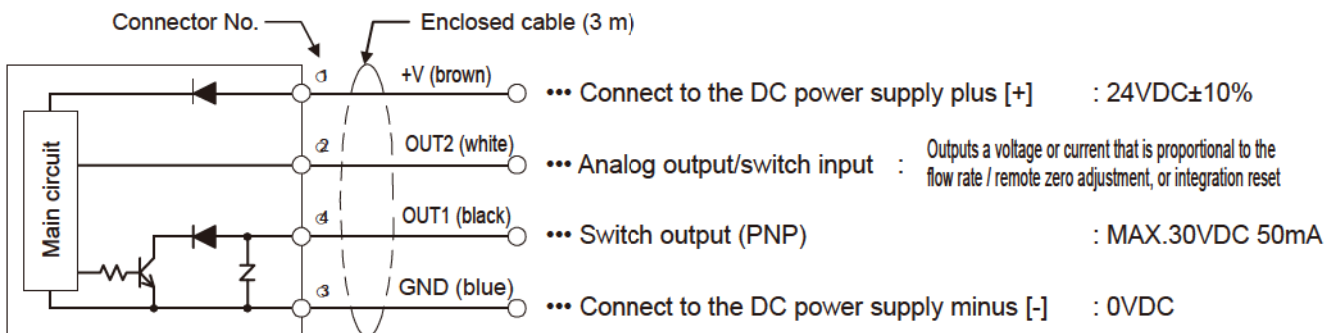

### 2)-PV, -PA

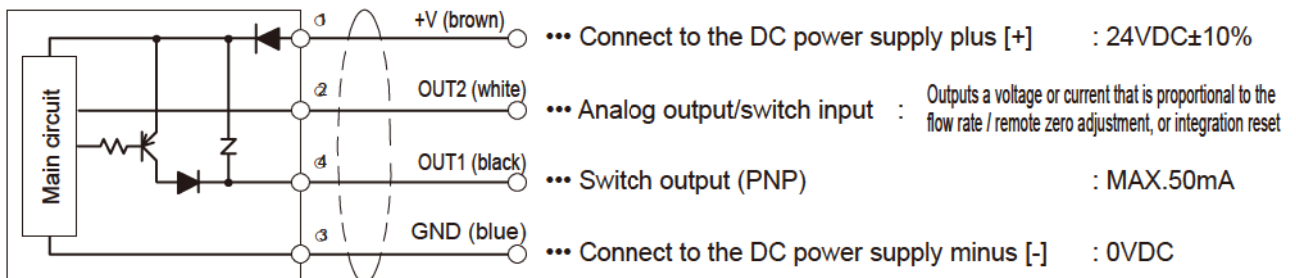

## Function explanation

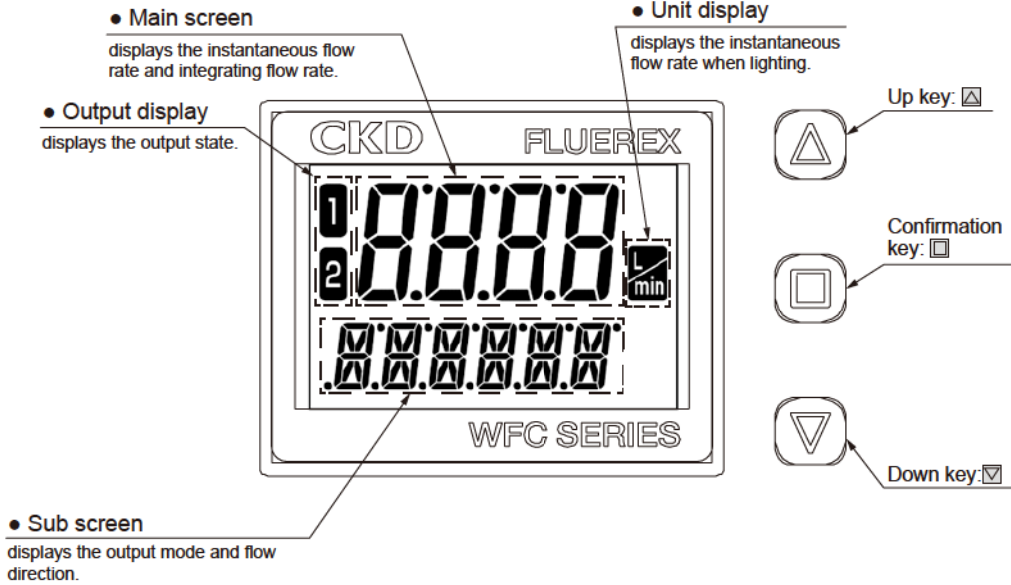







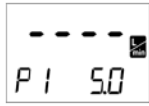

## Output mode and output operation

① Hysteresis mode	
② Window comparator mode	
③ Integration output mode	<ul style="list-style-type: none"> <li>• Increment mode           <ul style="list-style-type: none"> <li></li> <li></li> </ul> </li> <li>• Decrement mode           <ul style="list-style-type: none"> <li></li> <li></li> </ul> </li> </ul>
④ Integration pulse output	
⑤ Alarm output mode	
⑥ Analog output mode	<p>Instantaneous flow rate [L/min] 15 [L/min] (For voltage/Current output)</p>



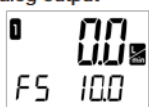
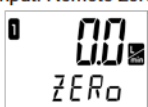

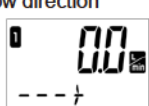
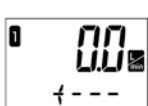
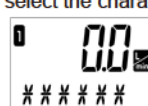
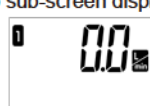







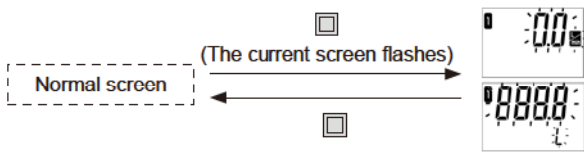

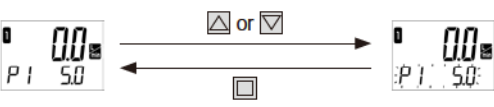



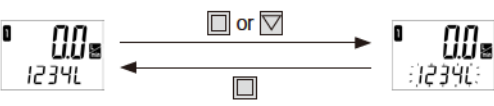

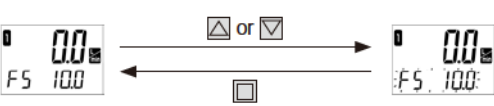



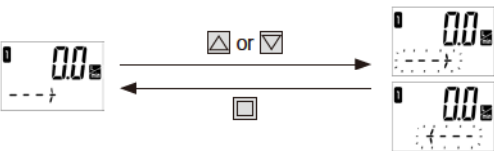

## Measuring mode

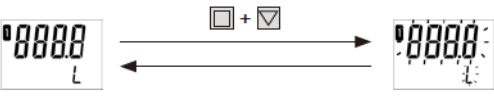
<Normal screen>

Instantaneous flow rate display	Hysteresis mode 	Window comparator mode 	Integration output mode 	Integration pulse output mode 
	Analog output 	Digital input: Remote zero adjust 	Digital input: Integration reset 	Alarm output mode 
	Flow direction 		Freely select the character 	No sub-screen display 
Total integration flow rate display 	Integration unit can be switched to "L", "KL", or "ML" with up key: ▲ and down key: ▼.			

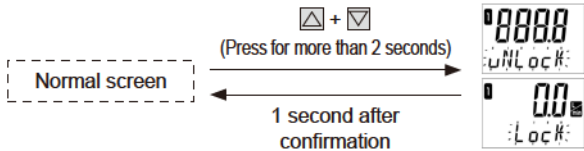
## Simple setting (short cut mode)

Using shortcuts, switching to the mode in which frequently used settings can be set from the usual screens.

Main screen		Select the "Instantaneous value display" or "total integrated value display", and confirm with  .
Hysteresis mode		Use  or  to set the determination value and confirm with  .
Integration output mode		Use  to reset integrated value.
Analog output mode		Use  or  to change F.S., and confirm with  .
Flow direction		Change the flow direction with  or  , and confirm with  .
Total integrated value reset		Use  to reset. Can be cancelled with  or  .
Key lock setting		Use  or  to change, and confirm with  .



# Safety precautions

Be sure to read the instructions before use

When designing and manufacturing a device using CKD products, the manufacturer is obligated to check that device safety mechanism, pneumatic control circuit, or water control circuit and the system operated by electrical control that controls the devices is secured.

Product selection, its usage and handling, as well as adequate maintenance management are important in order to safely use CKD products.

Observe warnings and precautions to ensure device safety.

Check that device safety is ensured, and manufacture a safe device.

## Warning

**1 This product is designed and manufactured as a general industrial machine part.**  
It must be handled by an operator having sufficient knowledge and experience in handling.

**2 Use this product in accordance with specifications.**

This product must be used within its stated specifications. Do not attempt to modify or additionally machine the product. In addition, since this product is intended for use in general industrial machine part, for use in outdoors (outdoor type excluded), or for use in the following environments and conditions are excluded.

(Note that this product can be used when CKD is consulted prior to use and the customer consents to CKD product specifications. The customer must provide safety measures to avoid risks in the event of problems.)

① Use for special applications requiring safety including nuclear energy, railroad, aviation, ship, vehicle, medical equipment, equipment or applications coming into contact with beverage or food, amusement equipment, emergency shutoff circuits, press machine, brake circuits, or for safeguard.

② Use for applications where life or assets could be adversely affected, and special safety measures are required.

**3 Observe corporate standards and regulations, etc., related to the safety of device design and control, etc.**

ISO4414, JIS B 8370 (Pneumatic system rules)

JFPS 2008 (Principles for pneumatic cylinder selection and use)

Including High Pressure Gas Maintenance Law, Occupational Safety and Sanitation Laws, other safety rules, body standards and regulations, etc.

**4 Do not handle, pipe, or remove devices before confirming safety.**

① Inspect and service the machine and devices after securing the safety of all the systems related to this product.

② Exercise caution as high temperature and charged parts can be present even when operation is stopped.

③ When inspecting or servicing the device, turn off the energy source (air supply or water supply), and turn off power to the facility. Discharge any compressed air from the system, and pay attention to possible water leakage and leakage of electricity.

④ When starting or restarting a machine or device that incorporates pneumatic components, make sure that the system safety, such as pop-out prevention measures, is secured.

**5 Observe warnings and cautions on the pages below to prevent accidents.**

■ The safety cautions are ranked as "DANGER", "WARNING" and "CAUTION" in this section.

 **DANGER** : When a dangerous situation may occur if handling is mistaken leading to fatal or serious injuries, or when there is a high degree of emergency to a warning.

 **WARNING** : When a dangerous situation may occur if handling is mistaken leading to fatal or serious injuries.

 **CAUTION** : When a dangerous situation may occur if handling is mistaken leading to minor injuries or physical damage.

Note that some items described as "CAUTION" may lead to serious results depending on the situation. In any case, important information that must be observed is explained.

## Disclaimer

**1 Warranty period**

Warranty Period of this product is one (1) year from the first delivery to the place you specified.

**2 Scope of warranty**

In case any defect attributable to CKD is found during the Warranty Period, CKD shall, at its own discretion, repair the defect or replace the relevant product in whole or in part, according to its own judgement.

Note that the following faults are excluded from the warranty:

① Product abuse/misuse contrary to conditions/environment recommended in its catalogs/specifications.

② Failure caused by other than the delivered product.

③ Use for other than original design purposes.

④ Third-party repair/modification.

⑤ Failure caused by reason that is unforeseeable with technology put into practical use at the time of delivery.

⑥ Failure attributable to force majeure.

The warranty stated here is related to the delivered unit itself. Damages caused by problems with the delivered item are excluded.

**3 Compatibility confirmation**

The customer is responsible for confirming the compatibility of CKD products with the customer's systems, machines and equipment.



Pneumatic components

## Safety precautions

Be sure to read the instructions before use.

Refer to "Pneumatic, Vacuum and Auxiliary Components CB-024SA".

### Design & Selection

#### ⚠ CAUTION

- Do not exceed the specified range of the product.
- This product is for liquid that does not corrode water or materials of wetted part over  $5\mu\text{S} / \text{cm}$ .  
Low conductivity liquid cannot be detected properly.
- Please do not use with a plus grounding.
- Please do not use in applications for which it is in direct contact with beverages, food, and medical fluids.
- Please do not use this product in flammable gas atmosphere.
- Please maintain fluid temperatures, and for usage in low temperatures, add such as antifreeze for freeze prevention measures.
- Please maintain the working pressure range during use.
- Please maintain the rated flow range during use.
- If considering lining up several units of this product in the flow capacity filling type device, please determine the use upon checking Patent No. 3916032.

### Installation & Adjustment

- There is a risk of electric shock on contact with electrical wiring connections.
- Turn power off before starting wiring.  
Do not touch the live parts with wet hands.
- Please ensure gas is not mixed in the piping.
- To change the settings, stop the equipment and change.
- 10 seconds after the power is turned on, since it is warm-up period, please do not use the display or output during this time.
- Please do not press setting switch with pointed material.
- Please do not install in locations exposed to strong light, such as direct sunlight or in a place which receives the radiation from heat sources.
- While the mounting orientation can be set freely, because it is less susceptible to the effects of bubbles, for lateral piping, it is recommended to mount the display surface horizontal to the ground.
- Please ensure proper setting of the flow direction of the piping and the flow sensor.
- Do not drop or hit it, or give excessive shock to it. In addition, please hold the body when handling. (Please do not hold cables)
- Please do not install in places where it will be exposed to strong compressive force, tensile force, load, or vibration after installation.
- Do not step on the product, or place heavy objects on them.
- Please note that applying excessive load can cause breakage.  
Please also ensure load from piping is not applied.
- Please ensure that sealing tape or adhesive do not protrude from the pipe threaded portion.
- Ensure that the piping just before the sensor is as straight as possible, so that there is no part such as protrusion of the packing that disturbs the flow.
- Please ensure flow regulating valve is installed downstream of the sensor.
- Please ensure to attach the sensor after cleaning in case of the presence of foreign matter or oil in the pipe.
- Faulty wiring may cause a malfunction.
- It is recommended that power and receiving instruments are electrically isolated from each other.
- Do not place excessive tension on the cable.
- Please do not wire with power lines.
- Please keep the product at a distance from power devices such as high voltage devices and motors, etc.

### During Use & Maintenance

- The product may be damaged by pressure rise due to temperature change in the liquid sealed circuit. Provide a relief valve so that a liquid ring circuit is not created.

## Related products

### Karman vortex type FLUEREX WFK Series

- Karman vortex detection method enables use in the environment with bad water quality
- A large effective sectional area realizes low pressure loss for energy saving of conveying pump
- Unique vortex frequency processing technology achieves a High response of 1.0 second
- Display of instantaneous flow and integrating flow rates is switched with a single touch
- 5-digit digital display (WFK5027/6027) is equipped to enable the integrating flow rate of the day to be viewed at a glance
- In addition to alarm output, an analog output useful for record control is equipped as standard

Catalog No.CB-024SA

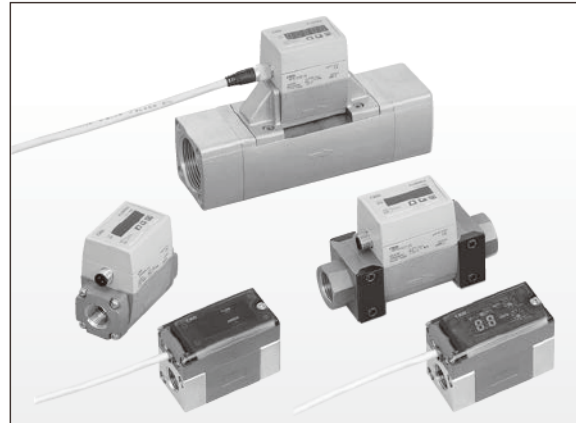

### Water integrated unit WXU Series

- Space saving and pipeless  
Installation space significantly reduced by unitization with discrete piping connection.  
Footprint 80% reduced compared to CKD previous models (2-fluid control type)
  - Improved quality  
Due to no screwed piping between components, the fear of external leak is eliminated.  
No entry of foreign matter when installing.
  - Man-hours reduced  
Man-hours for troublesome piping design, piping work, material arrangement etc. are reduced significantly
- \* Flow sensor loaded in WXU Series is WFK Series (Karman vortex).  
Consult with CKD regarding WFC Series

Catalog No.CC-1116A

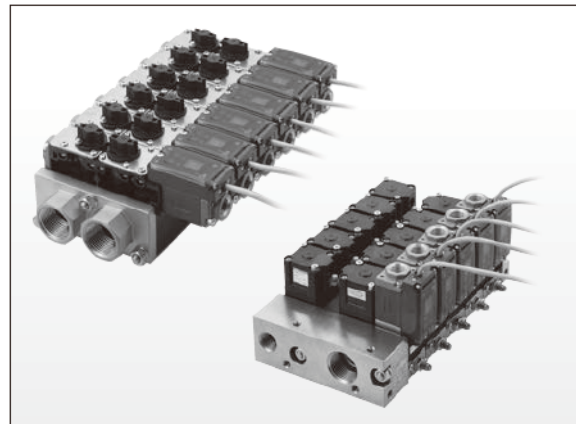

If the goods and their replicas, or the technology and software in this catalog are to be exported, laws require the exporter to make sure they will never be used for the development or the manufacture of weapons for mass destruction.

## CKD Corporation

<Website>  
<http://www.ckd.co.jp/>

Head Office • Plant	2-250, Ouji, Komaki, Aichi 485-8551	TEL(0568)77-1111	FAX(0568)77-1123
Overseas Sales Administration dept.	2-250, Ouji, Komaki, Aichi 485-8551	TEL(0568)77-1338	FAX(0568)77-3461
Tokyo Branch Office	4F, Bunkahousou Media Plus, 1-31-1, Hamamatsu-cho, Minato-ku, Tokyo 105-0013	TEL(03)5402-3620	FAX(03)5402-0120
Nagoya Branch Office	2-250, Ouji, Komaki, Aichi 485-8551	TEL(0568)77-1356	FAX(0568)75-1692
Osaka Branch Office	1-3-20, Tosabori, Nishi-ku, Osaka 550-0001	TEL(06)6459-5770	FAX(06)6446-1945